

Comp side - ETR 220
 Solder side - 3033 05-220-7001-0 0e
 Date coded - May 73

RevNo	Revision note	Date	By	Checked
-	-	-	-	-

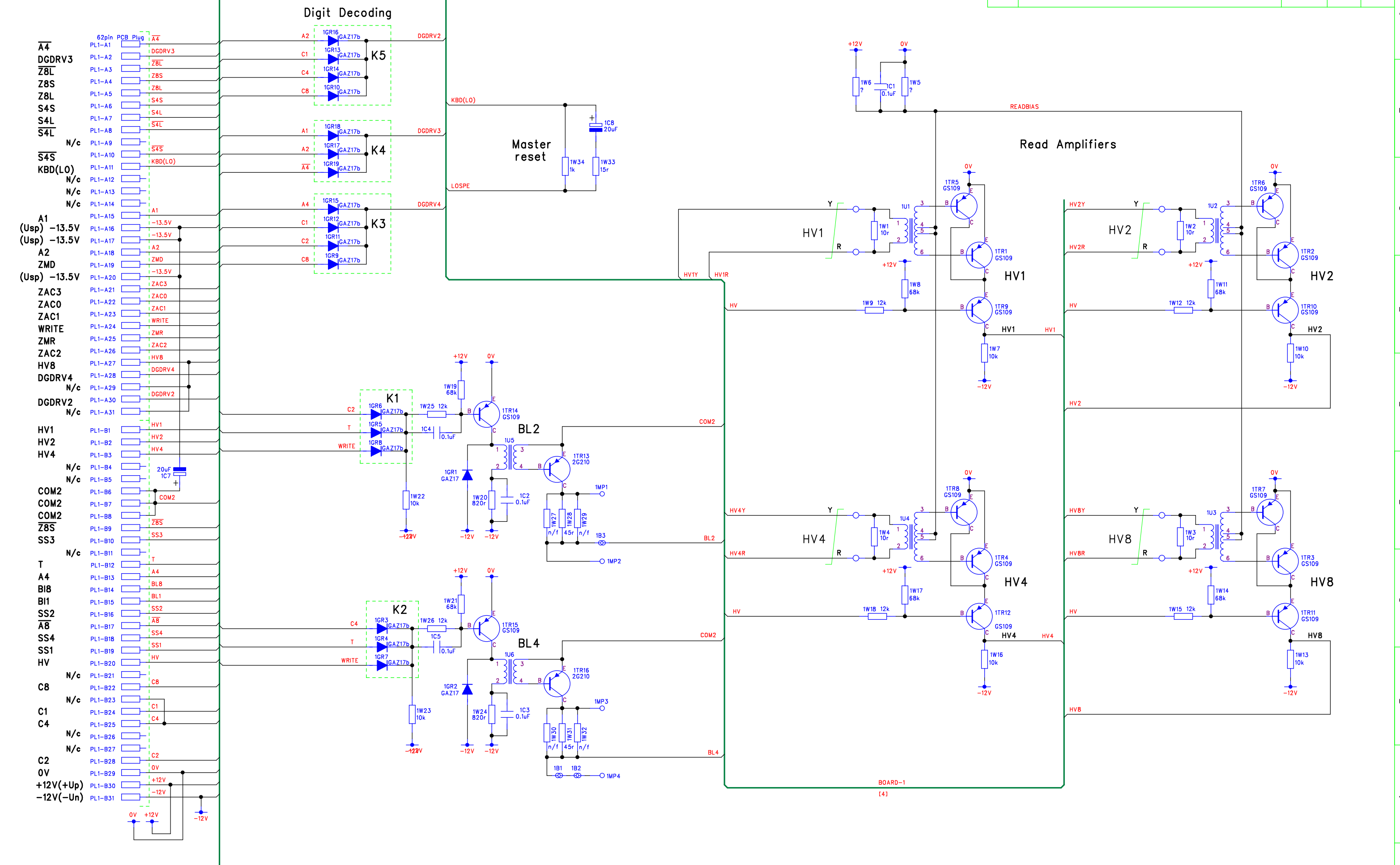

These diagrams are referenced to 0V - Logical 1 = -12v, logical 0 = 0V



DM Associates
 33, Northbrook Road
 Aldershot, Hampshire. GU11 3HE
 Email: mike@soemtron.org
 www.soemtron.org

Pcb Dwg # =		Scale	Nts	Title	
Drawn	Name	Sheet	3	Soemtron ETR 220 Calculator	
Checked	Date	Next Sheet	4	Digit Decoding & Read Amps	
		Drawing Number		BOARD 1	
				Soemtron 220	A2 Issue A

RevNo	Revision note	Date	By	Checked
-	-	-	-	-

Lö SPE only clears the MD, MR and ACO registers

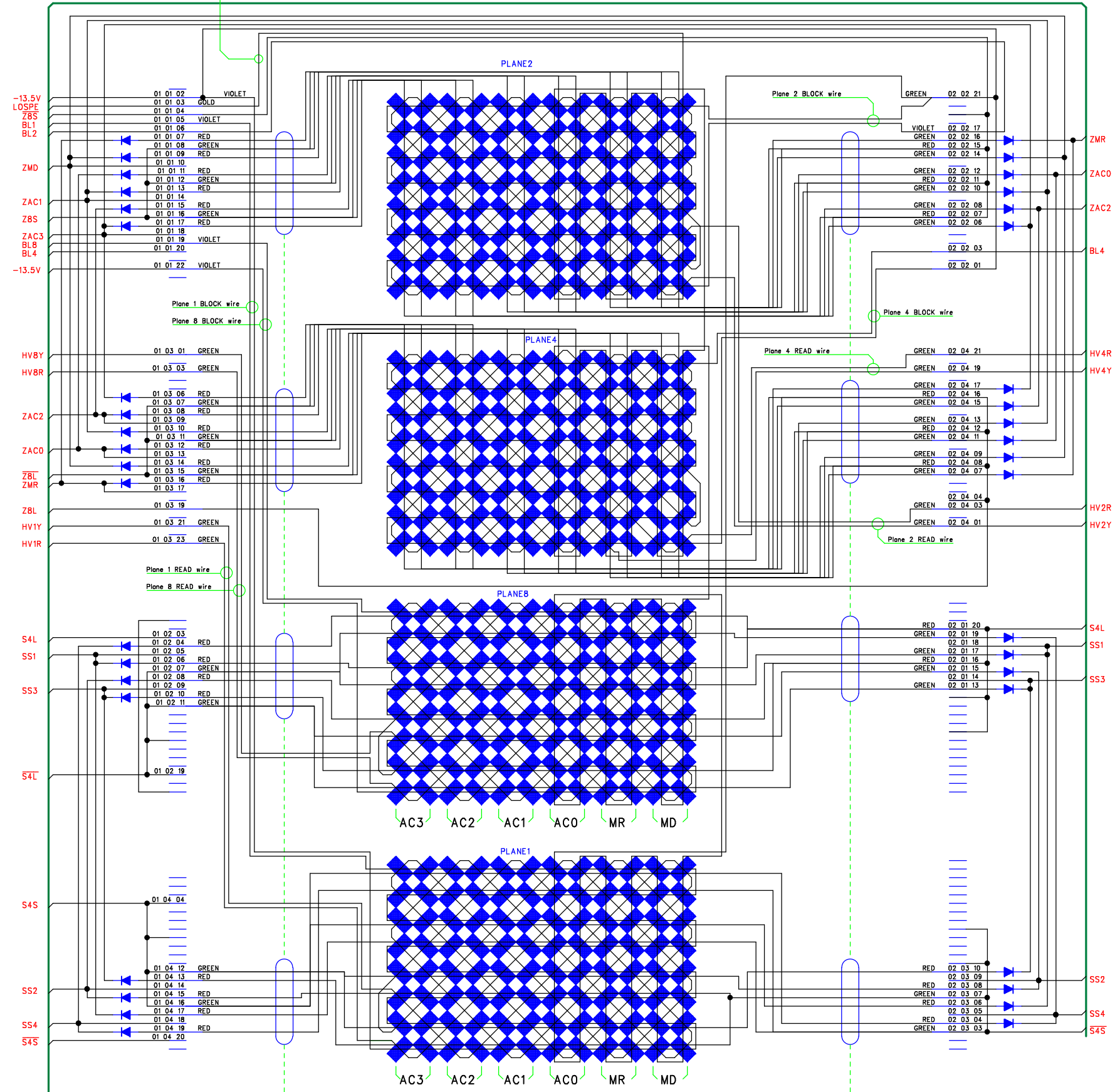

Each of these eight groups of ROW / COLOUMN wire sets is shown passing through one plane only. They actually pass through all four planes.

These diagrams are referenced to 0V - Logical 1 = -12V, logical 0 = 0V



DM Associates
 33, Northbrook Road
 Aldershot, Hampshire. GU11 3HE
 Email: mike@soemtron.org
 www.soemtron.org

Pcb Dwg # =		Scale	Nts	Title	
Drawn	Name	Sheet	4	Soemtron ETR 220 Calculator	
Checked	Date	Next Sheet	5	Core Store - Planes	
		Drawing Number		BOARD1 Sheet 2	
				Soemtron 220	A2 Issue A

© 2008 Mike Hatch. (www.soemtron.org)